

Scenarios for Consuming Standardized Automated Demand Response Signals

Ed Koch
Akuacom

Mary Ann Piette
Lawrence Berkeley National Laboratory

- Where do DR signals originate and where are they consumed?
- Where is the DR Logic?
- What role do intermediaries play?
- What is the nature of DR signals?
- What role can standards play?

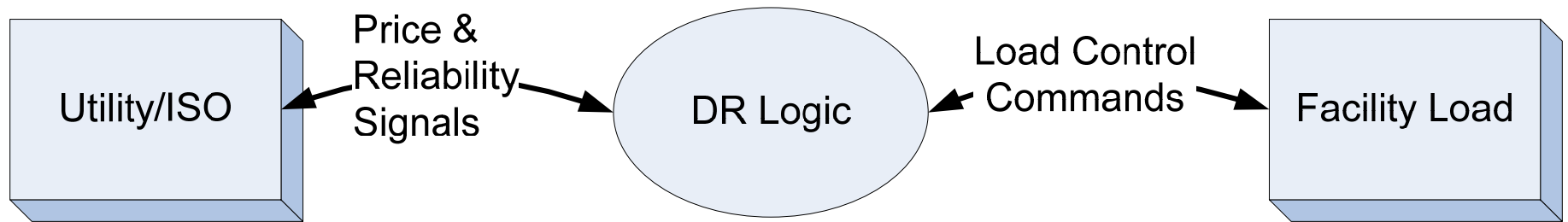

DR Infrastructure in Facility

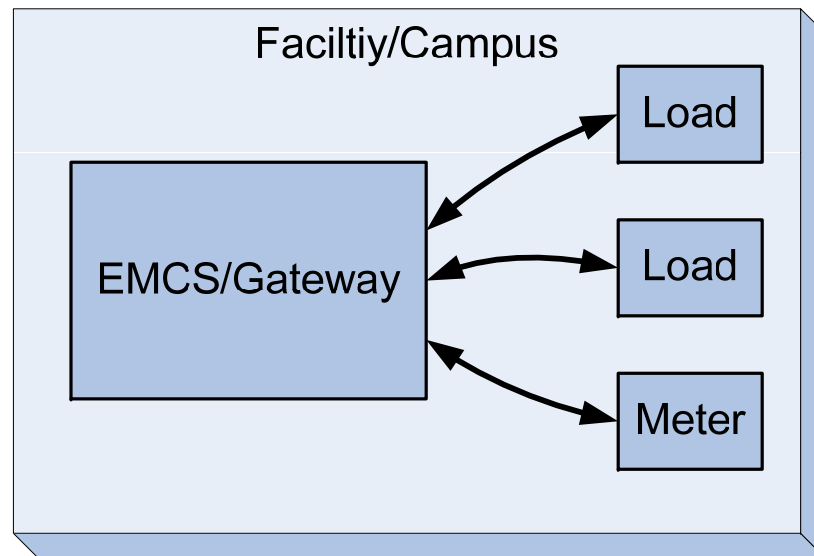

DR Logic with Respect to Facility

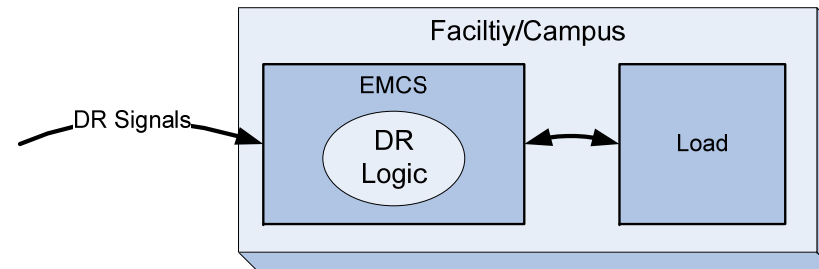

DR Logic in EMCS

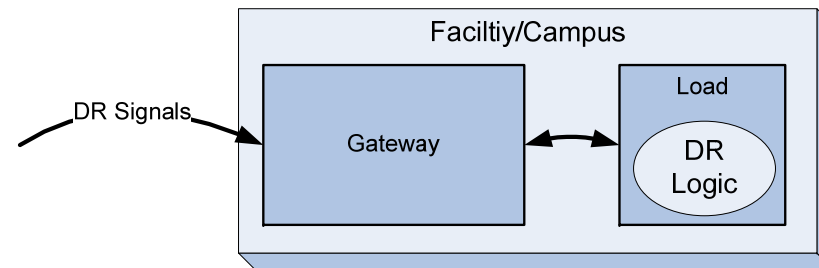

DR Logic in Load Controller

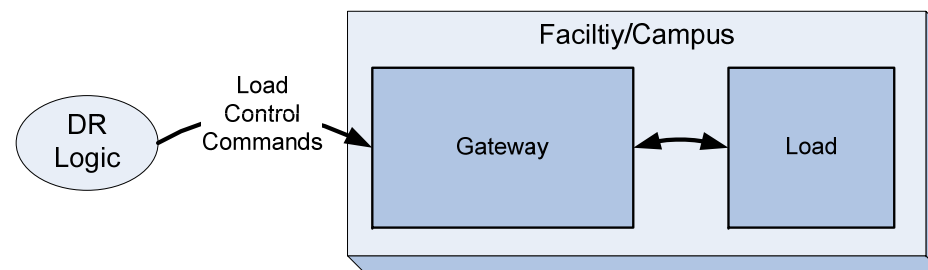

DR Logic External to Facility

DR Intermediaries

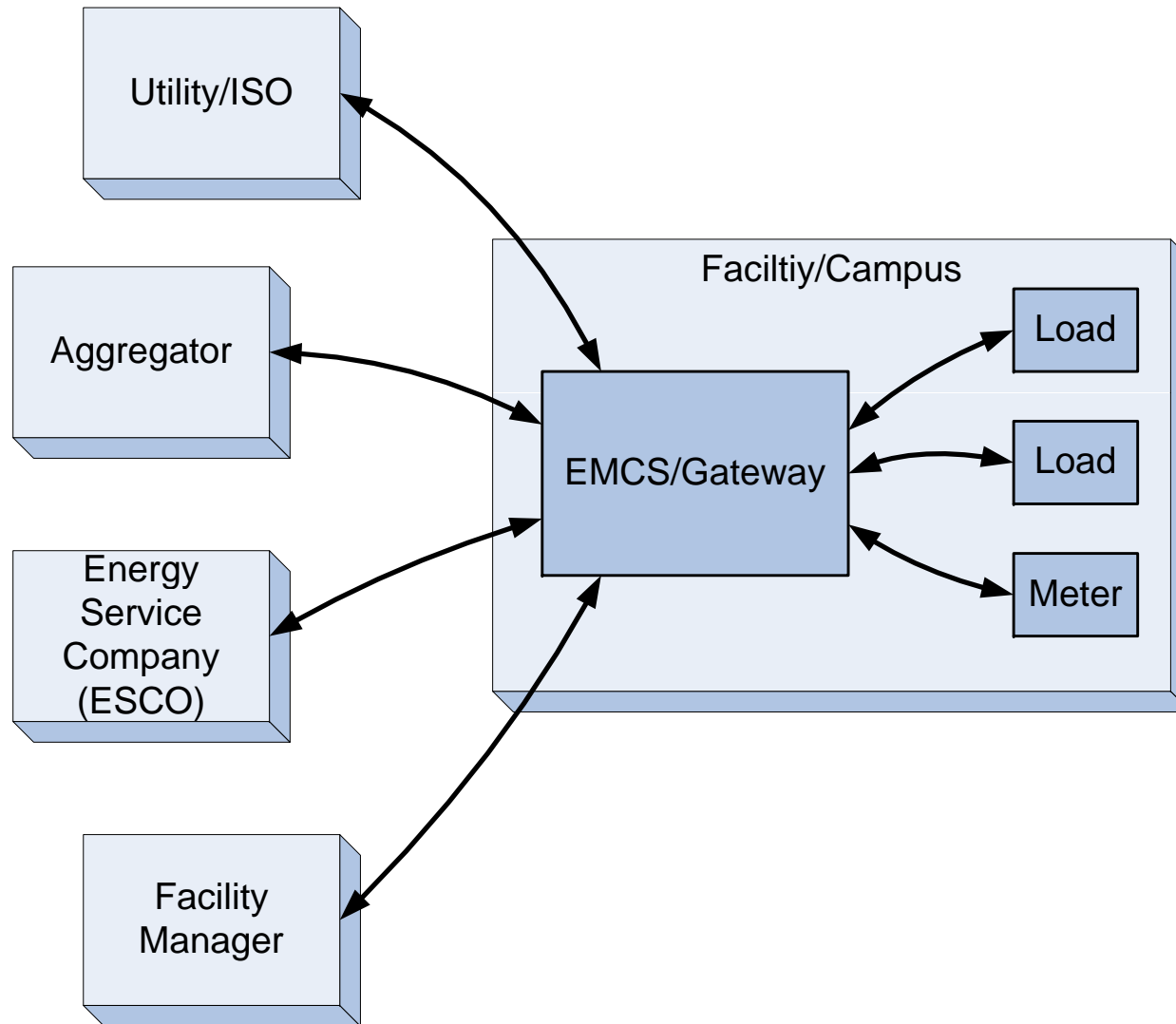



Utility/ISO: Direct Load Control

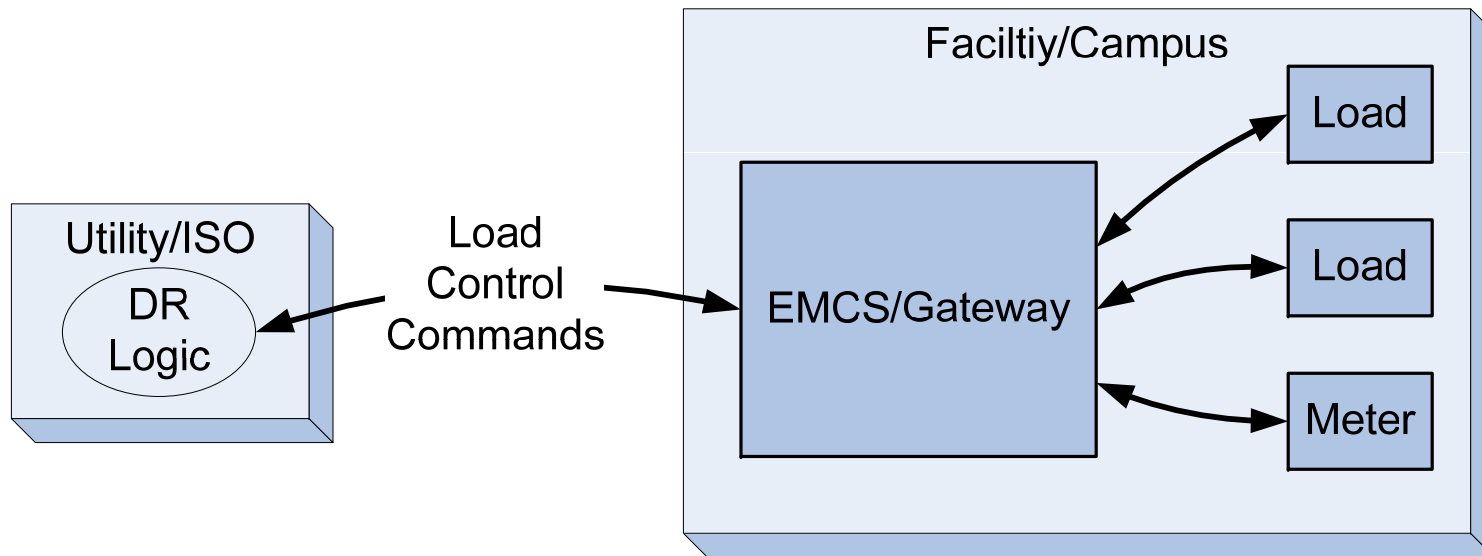

Utility/ISO: DR Logic in Facility

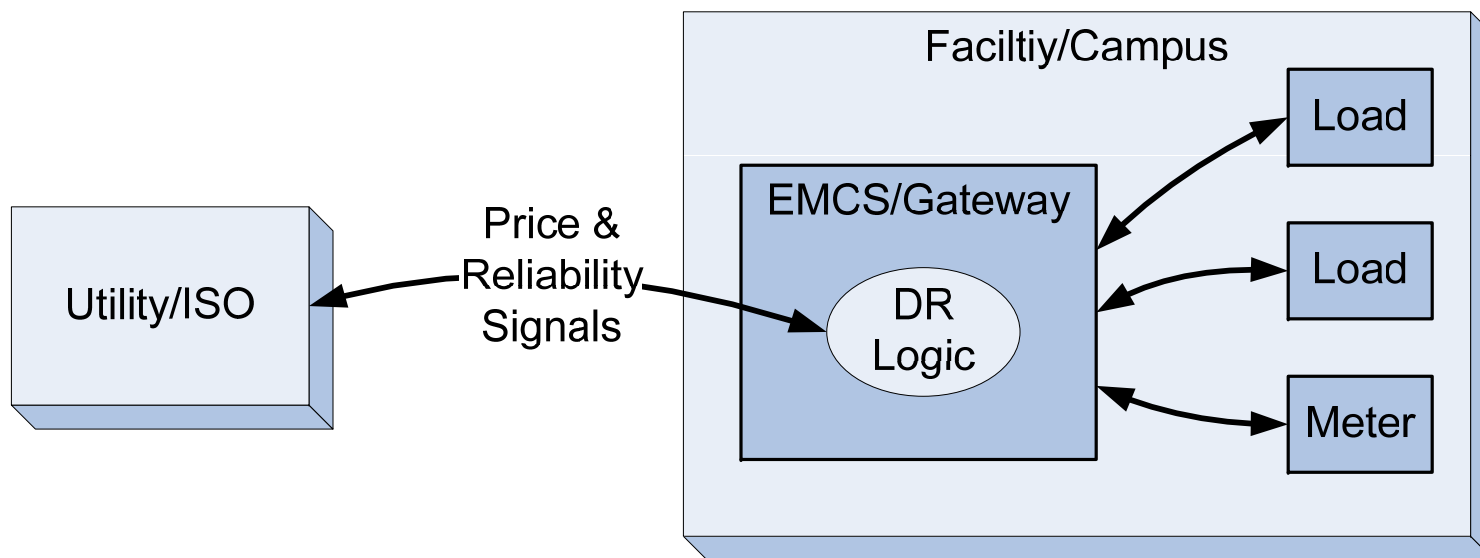



Intermediary - Aggregator

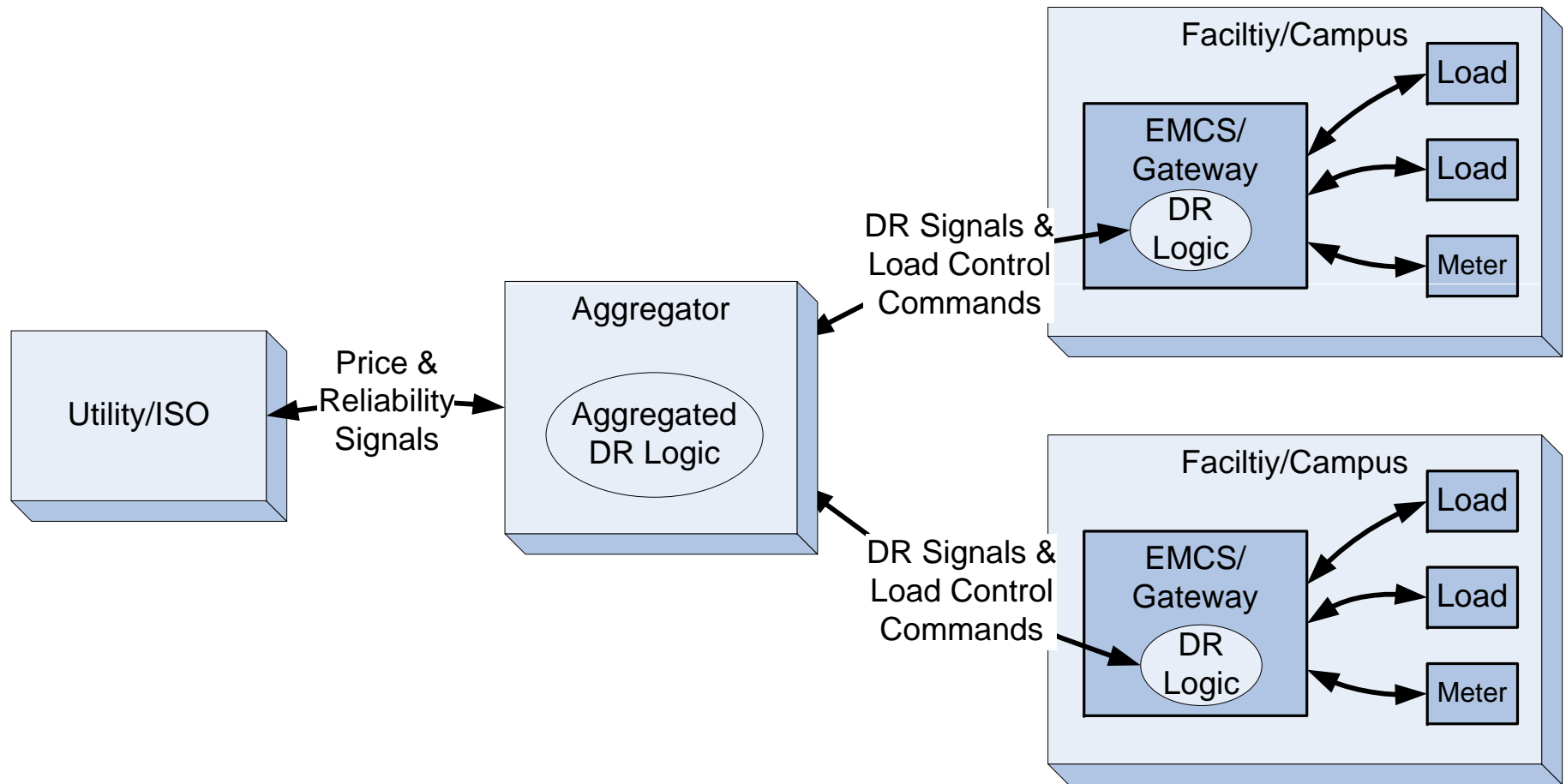



Intermediary - Energy Service Company

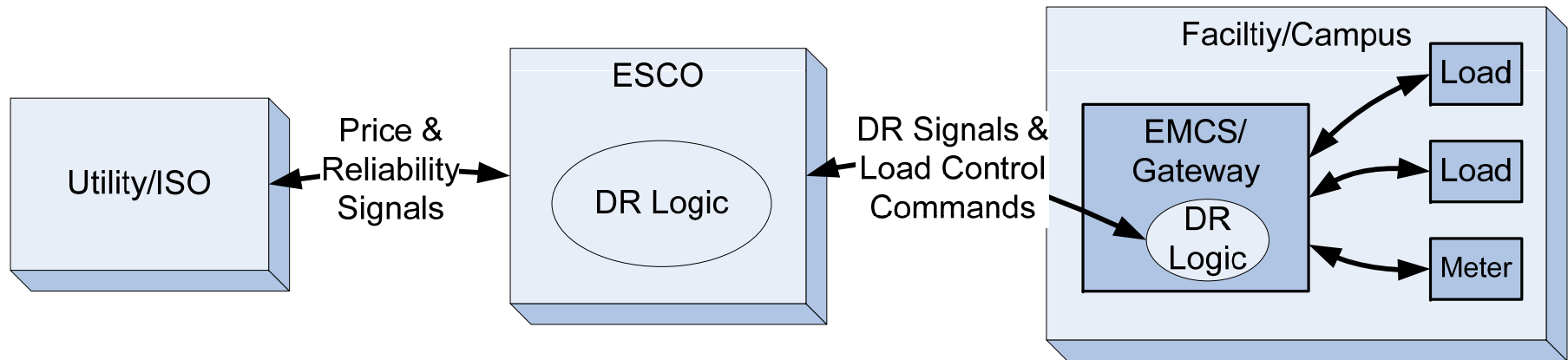



Intermediary – 3rd Party Facility Manager

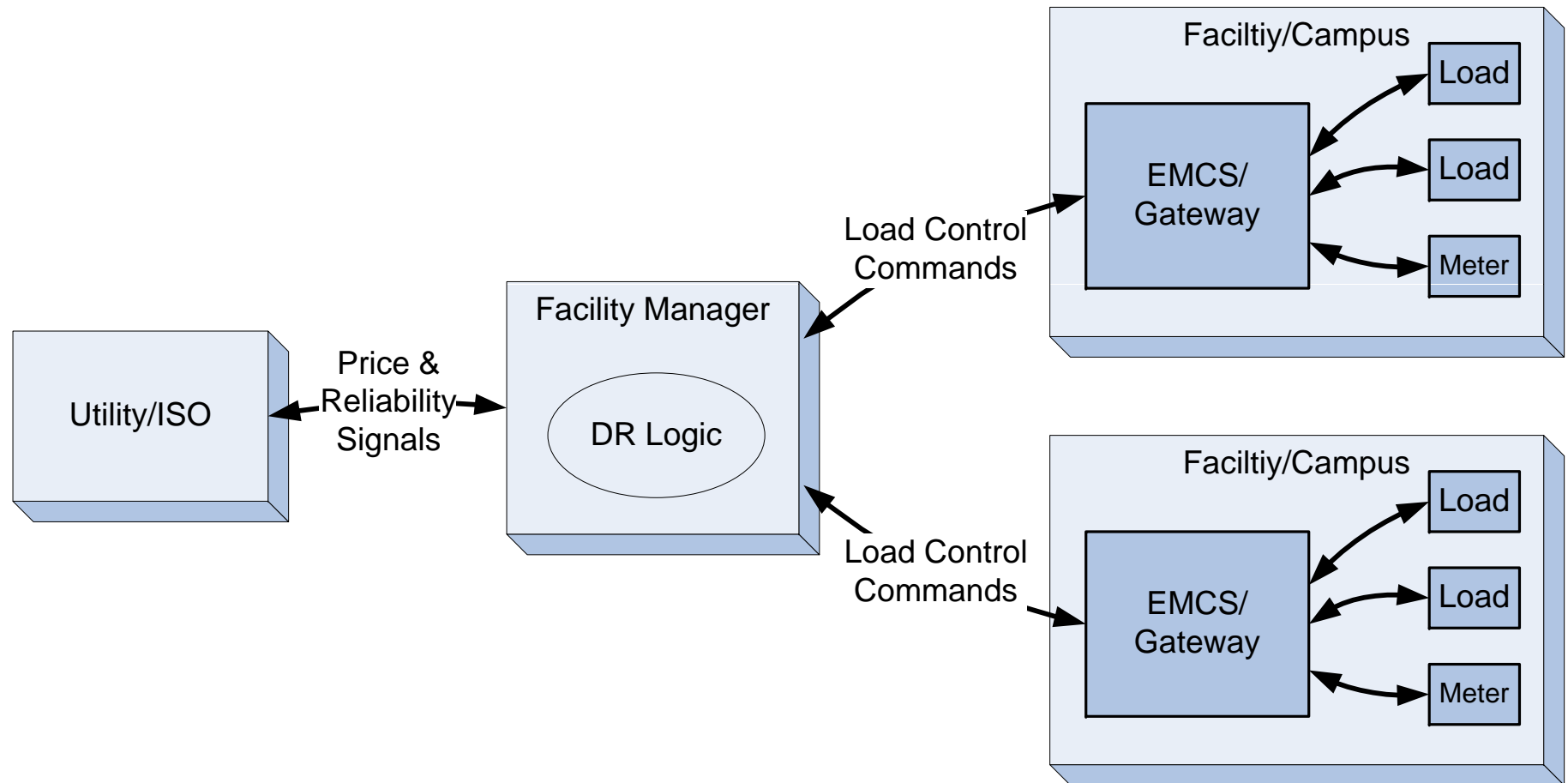

- It should use widely adopted forms of representation (i.e. XML).
- The schema used to encode the information in the DR signal should be simple enough to allow lower end devices to process it.
- The complexity of the information should be such that simple rules can be devised by non-IT professionals (i.e. facility managers) to allow the DR Logic to be specified.
- The DR signal should be designed such that it can be delivered using widely deployed networking infrastructures (i.e. IP and Web Services).
- The DR signal should be designed so that it can be delivered in a secure and non-repudiated fashion.



DR Signal Contents

- DR Event information.
- Schedule of DR Event and business information.
- Ancillary information.
- Intermediary specific information.
- Simplified DR Event representation.

Standardized DR Signal

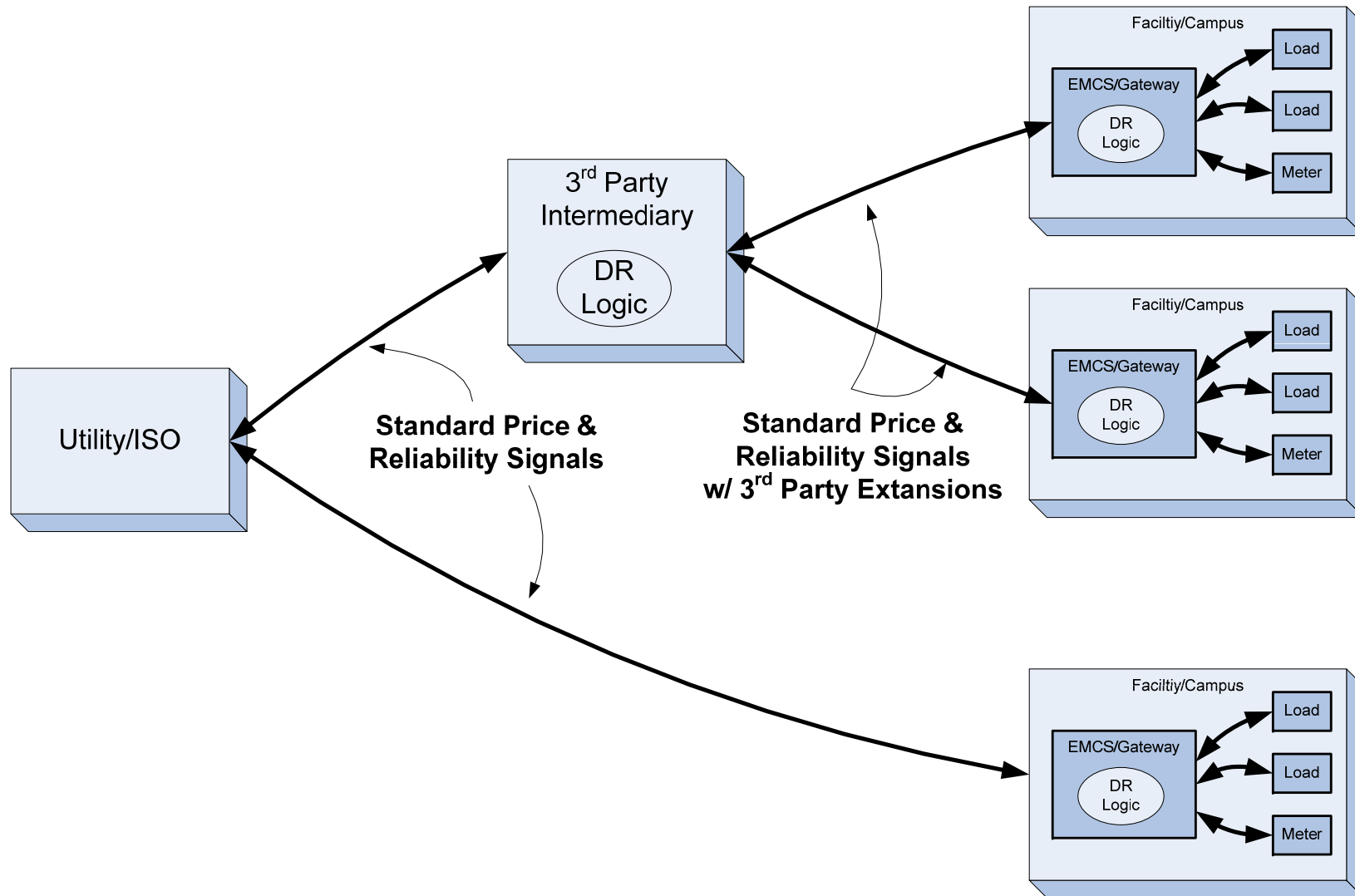



A Strategy for Developing Open DR Signaling Standards

- Work with organizations such as OpenADR to address DR specific domain and cross cutting issues in an open and public forum.
- Work with Utilities and ISO's to address utility infrastructure issues and requirements for DR programs.
- Work with facility automation organizations such as BACnet, Lonmark, OPC, oBIX, etc. to address issues relevant to facilities.
- Work with organizations such as OASIS to address issues relevant to business and enterprise level transactions.
- Work with end user organizations such as Retail Energy Alliance and Green Grid to address end user issues.
- Work with standards organizations such as NIST, OpenAMI, EPRI, UCA, IEC, IEEE, etc. to address utility infrastructure issues and harmonize with other standards.
- Recruit participation from intermediaries to address their issues.